

Our Experience Is The Shaping Of The Uppers



Multiform 3

Versatile Backpart Moulding Machine With Two Hot & Two Cold Stations



Back-part moulding



Normal flanging



Mini - counter flanging



Stitch Down flanging
(On demand) **NEW**



Moccasin Flanging
(On demand)



Goodyear flanging
(On demand)

5

**Different shaping
procedures
in one machine**



VERSATILE BACKPART MOULDING MACHINE WITH TWO HOT & TWO COLD STATIONS

Multiform3 distillates 40 years of experience and development into the back-part moulders. It combines all the advantages of the previous POLYFORM generation machines with those of Multiform99, and creates a very dynamic and economic unit that offers all the quality you could ask. Multiform3 shapes with the same ease high quality women's, men's and children's uppers, as well as boots, and mini counters.

Thermoplastic or leatherboard counters

The standard version of this machine is equipped with two hot and two cold stations for thermoplastic counters, but it can be delivered on demand with four hot stations for maximum results on leatherboard counters too.



Multiform³

Back-part moulding

Pincers with inclination

The pincers of the Multiform3 is a new developed system which can easily take inclination for high heel uppers.

- Easy angle adjustment
- Quick adjustment

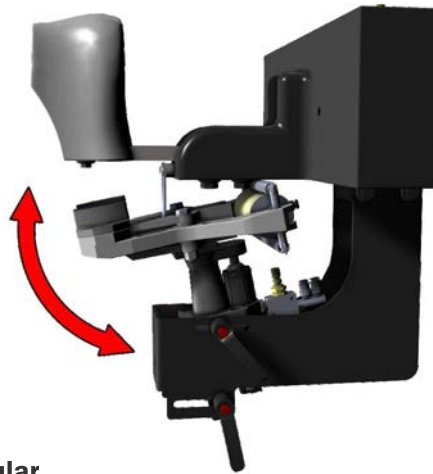

Cushion with intergrated wipers & tubular

The Multiform3 is equipped with a patented cushion with integrated olympic wipers of Olympic which ensure a high parametric pressure on the upper in combination with excellent upper flanging.

* NEW FEATURES

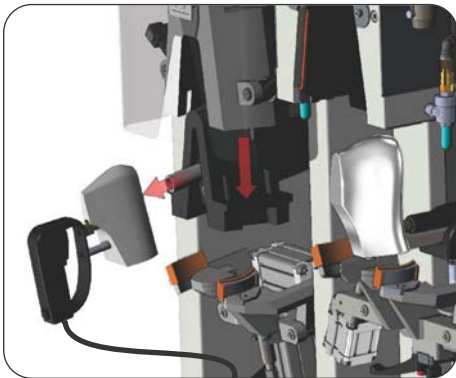

New quick release hot station mould system (On demand)

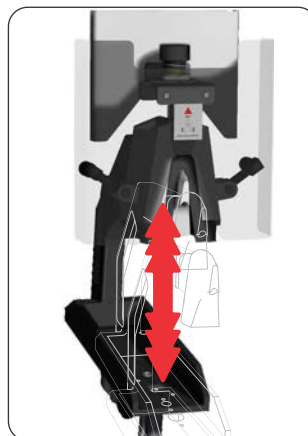

New stitch hammering function (On demand)

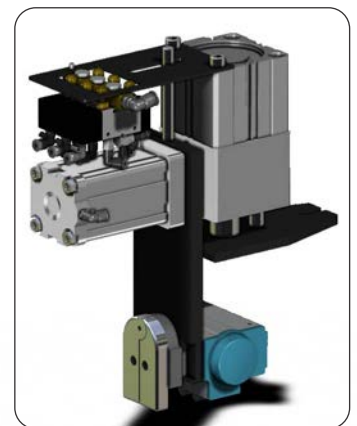

**Brand new
STITCH DOWN DEVICE**
(On demand).

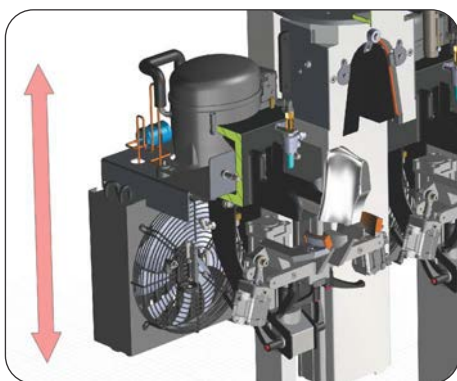

New redesigned moving cooling unit system with life time warranty



New redesigned led projector for accurate upper positioning

Back-part moulding

ROTATING CUSHION SYSTEM WITH INTEGRATED WIPERS

The patented cushion of Multiform3 can be rotated in seconds making difficult procedures simple...

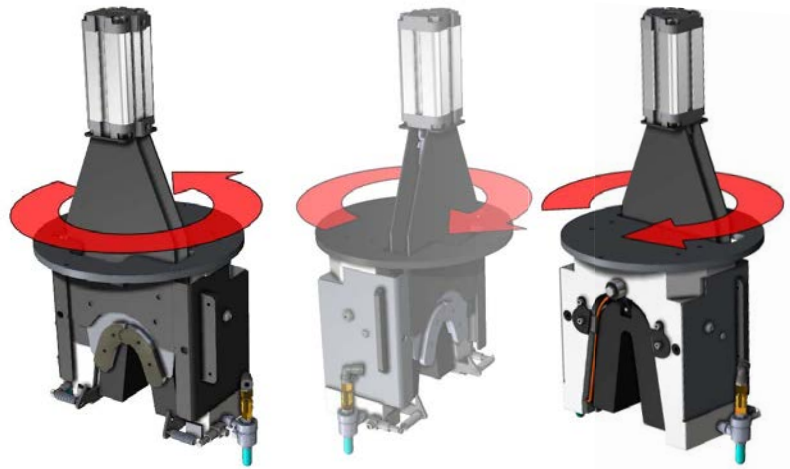

Mini counter moulding

Conversion time 2Min



Moccasin moulding

Conversion time 5Min



Multiform fits in any production

Conversion time 10Min



Cushion with integrated wipers & tubular

- Male-female moulds
- Thermoplastic counter
- Flanging



Inflatable Cushion without wipers

- Universal moulds
- Extra shaping pressure
- No flanging
- Suitable for thermoplastic and leatherboard counters



TECHNICAL DATA

OPERATION	Electro - Pneumatic
PRESSURE	6 Bar
CAPACITY	1100 pairs per 8 hours max.
VOLTAGE	230V single phase 50Hz
POWER CONSUMPTION	2500 W
DIMENSIONS (mm)	1660 X 855 X 2030h
WEIGHT	560Kgs